

Pre delivery guide

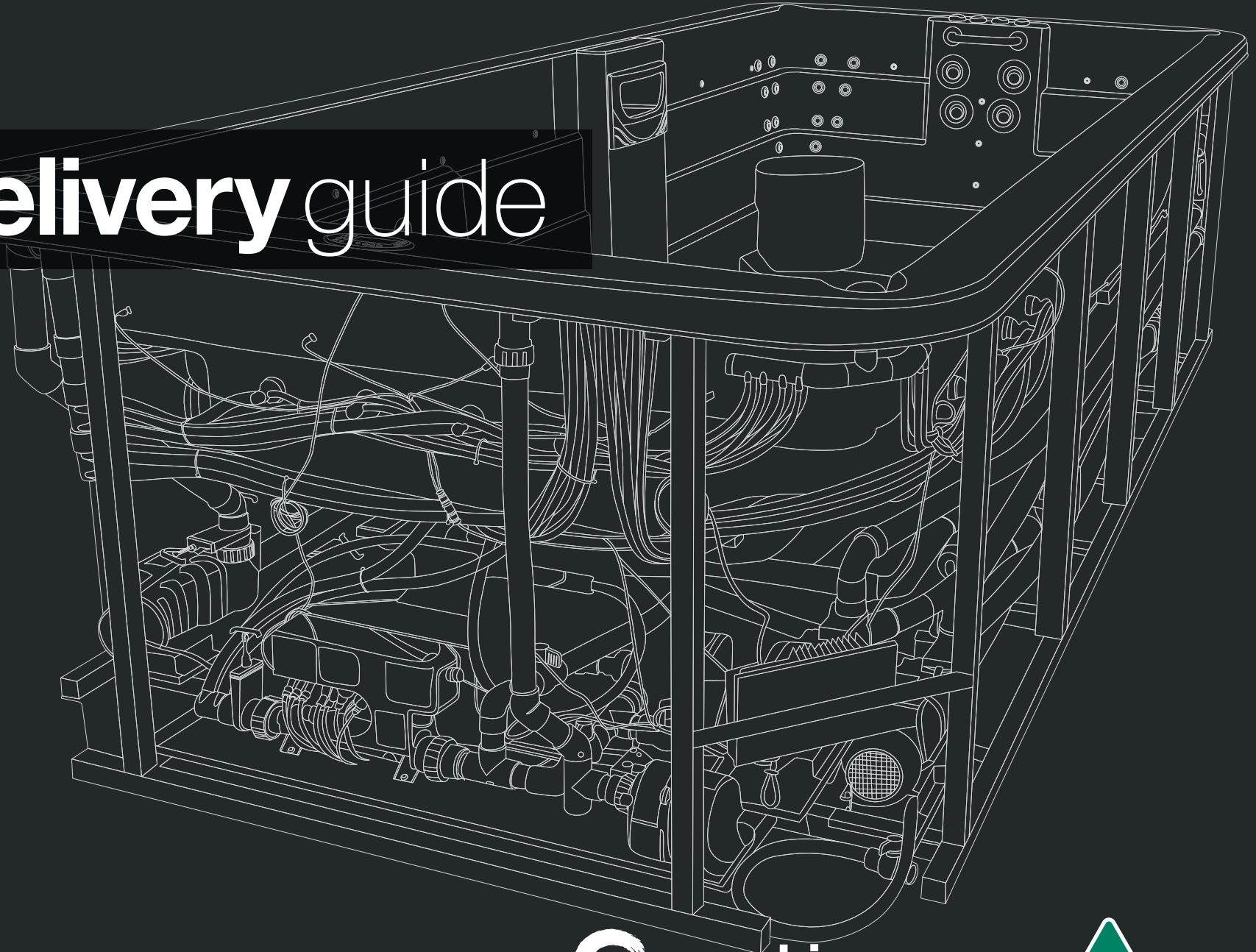

 **sapphire spas.**
australian made & family owned





Welcome to our family

As part of the Sapphire family our level of care doesn't end once you hand over the money. Remember that, as a Sapphire Spa owner, you're protected by our lifecare commitment; just contact the team at your local store.

Take the time to look through 'WELCOME to our Family' tab on our website:

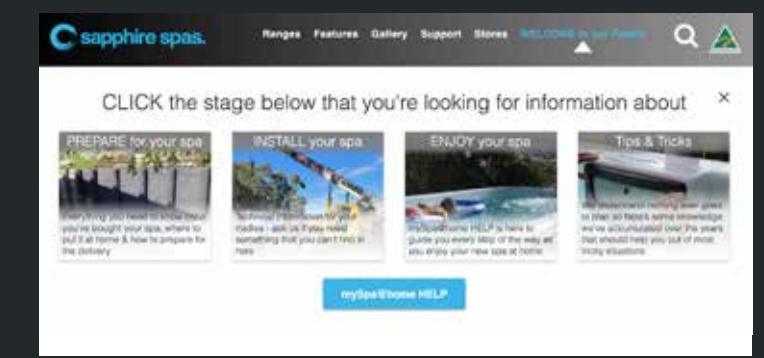

PREPARE for your spa

Everything you need to know once you've bought your spa, where to put it at home & how to prepare for the delivery.

INSTALL your spa

Everything you need to know as you're installing your spa, including technical information for your tradies.

ENJOY your spa

We know all you want to do is jump in – nobody wants to read the manual! As part of the Sapphire Family we're here to guide you every step of the way with simple instructions & practical videos, as you enjoy your new spa at home.

Tips & Tricks

We understand nothing ever goes to plan so here's the knowledge we've accumulated over the years.

mySpa@Home help

is a comprehensive collection of 'how to' videos, manuals & quick references guides to have right by your side as you enjoy your new purchase.





Prepare we're here to help

Please take the time to read these instructions thoroughly as they will provide you with information to ensure the safe and timely delivery and installation of your new spa pool or swim spa.

The information to follow should be used as a guideline on how to prepare for delivery and set up of your spa. We have specifically detailed requirements for site selection, delivery access, ground preparation and electrical requirements.

Please carefully review the Owner's Manual that you will receive with your new spa and register your spa's warranty within 10 days of delivery to guarantee ongoing assistance and support. This manual should be found in your spa when delivered.

Sapphire Spas reserves the right to change features, specifications and design without notification and without incurring any obligation.

IF YOU ARE UNSURE OF ANY ASPECT OF THE SITE PREPARATION PLEASE CONSULT YOUR SAPPHIRE SPAS RETAILER FOR CLARIFICATION

Regulations

It is important that home owners comply with state and council regulations which are in place to improve safety outcomes. Additional information can be obtained from your local council or visiting spasa.com.au.

Safety considerations

- Your spa cannot be positioned within three (3) metres of overhead power lines or existing power outlets.
- A qualified electrician must be consulted to complete all electrical requirements necessary for your new spa pool.
- Temporary and permanent fencing may be required to comply with council regulations.
- Sapphire Spas will not be held responsible for any issues arising from these safety or compliance requirements.
- A copy of the Electrical Safety Certificate may be requested by your dealer or the manufacturer if requesting a warranty claim.
- It is recommended that a separate circuit be dedicated to your spa pool with sizing and amperage dependant on the type of spa pool and the equipment used.
- All other regulations must be adhered to and Sapphire Spas will not be held responsible for any actions taken by yourself or any technicians that may void warranties or violate local authorities' regulations and laws.

Electrical requirements

- The electrical connection to your Sapphire portable spa pool is your responsibility.
- You must ensure that all regulations and codes are adhered to. The connection must be completed by a qualified electrician who must supply an Electrical Safety Certificate.

DAMAGE TO YOUR SPA DUE TO INCORRECT ELECTRICAL REQUIREMENTS WILL NOT BE COVERED BY YOUR SAPPHIRE SPAS WARRANTY.



Preparation onsite

Once you have selected a site for your new spa, ensuring there is 600mm clearance around spa, you'll need to prepare a solid, level and supportive base which will remain stable for the life of your spa.

A typical spa in use poses a considerable weight for any foundation to support. Even our smaller spas can weigh up to 2000kg when filled with water and occupants, some of our larger models can reach 3000kg and our swim spa up to 7000kg.

Refer to your brochure for dimensions and approximate filled weights of Sapphire Spas models.

Remember, weight of occupants must also be considered in addition to these figures.

Do not put your spa on any soft surface such as grass, sand, pebble or dirt as this may place undue stress on your spa, causing it to distort and/or crack.

Damage caused by an inadequate foundation will void the warranty on your spa. It is the owner's responsibility to ensure correct installation of the spa.

Whether choosing a concrete slab or timber decking to support your spa pool, Sapphire Spas strongly recommend the use of a licensed contractor.

Concrete slab

A reinforced concrete slab of at least 100mm (4") thick is a suitable foundation for your spa; this must be increased to a minimum of 150mm (6") thick reinforced concrete slab when installing swim spas. You must ensure this base is an even, level surface free from cracks, doming or hollows. It's preferable for the slab to extend at least 200mm outside the spa dimensions for stability.

Timber decking

Sapphire Spas recommend that you consult a structural engineer to ensure that your decking is capable of safely and adequately supporting the full weight of your spa when in use. Should you wish to surround your spa with decking, we suggest that you install it on a concrete slab (as above) then build the deck to surround your spa.

SAPPHIRE SPAS WILL TAKE NO RESPONSIBILITY FOR THE INSTALLATION OF YOUR SPA



Preparation delivery

Prior to the arrival of your new SpaPool or SwimSpa, please ensure clear access is available from the delivery vehicle (crane, truck, ute etc.) to the selected location for your spa.

Consult your dealer for details of space required to manoeuvre and park. The driver will make every effort to get as close to the site as possible to unload your spa. You will need to be on hand for the delivery and ensure you provide enough manpower to manoeuvre the spa onto site. Consult your dealer in relation to assistance such as trolleys.

Check the dimensions of your spa as per your brochure. Your spa may be tilted onto its side to fit through a smaller pathway, but you need to then allow for the increased height of the spa and any trolley being used.

Always use a reputable crane or delivery company who can provide proof of insurance on request.

More difficult sites

Please consult your Sapphire Spas store to discuss further measures should you not meet the recommended requirements. A crane is sometimes necessary but is not included in a standard delivery price.

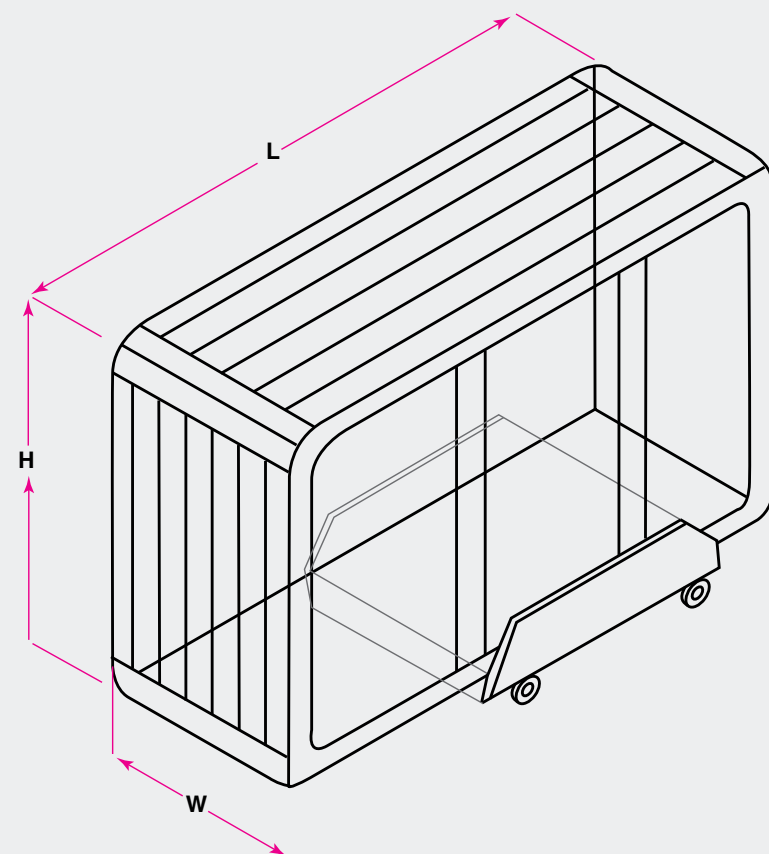

Restrictions delivery route

Please consider these possible restrictions which may apply to your selected delivery route:

- The width of all doorways, gates and pathways.
- The height of low trees, roof eaves, guttering or telephone lines.
- Tight bends to be negotiated, ex. 90 degree turn (take measurements).
- Obstruction from protruding fixed objects, ex. meter boxes, a/c units, hot water services etc.
- You may have to cut or tie back shrubs or trees, move dog kennels, bbq's, planter boxes or wood piles.
- Severe slopes along the route which may cause trouble.

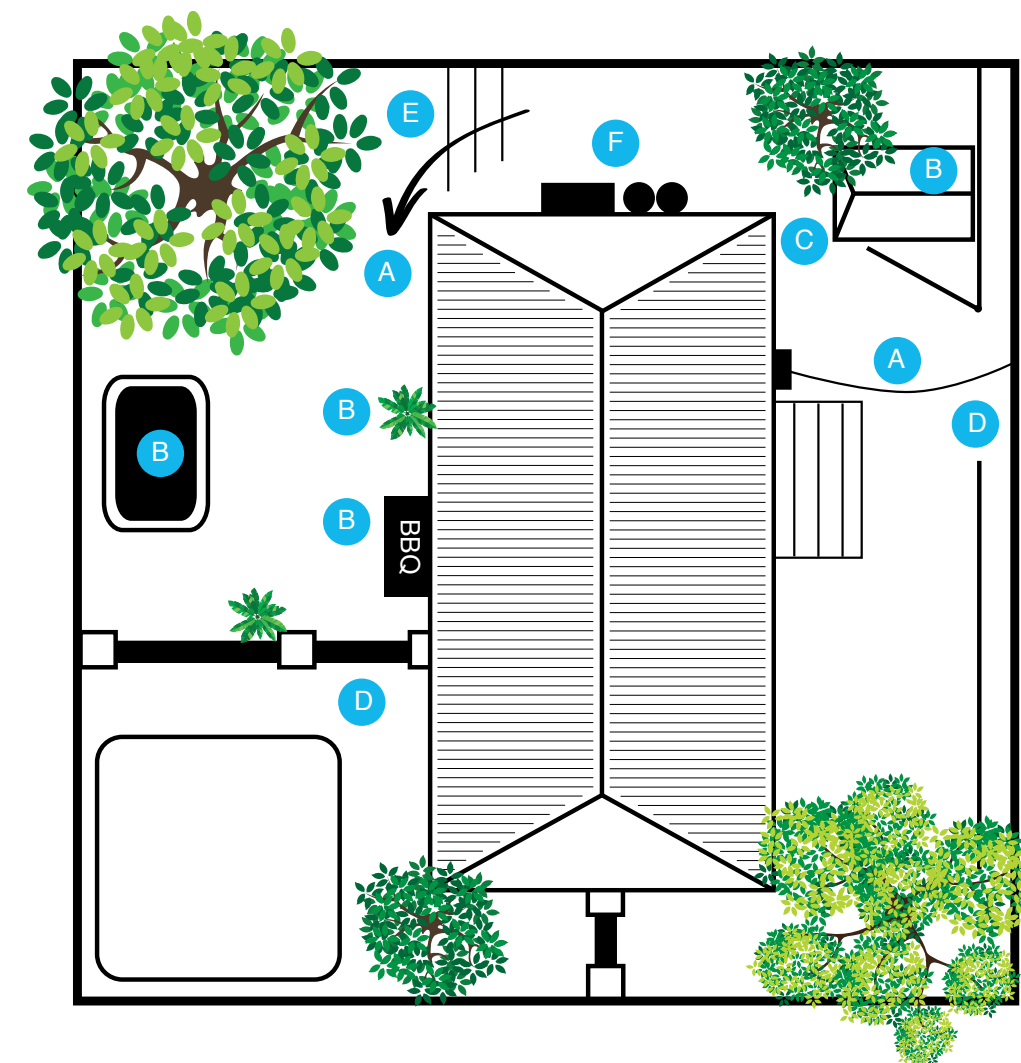

- A.** Check height of low trees, roof eaves, guttering, phone lines.
- B.** Move dog kennels, bbq's, planter boxes, kids play equipment.
- C.** Check corner clearances.
- D.** Check width of doorways, gates & pathways.
- E.** Advise of steep slopes & number of steps.
- F.** Check meter boxes, a/c units, hot water services, water/gas meters.

Location heat&cool pump pipes

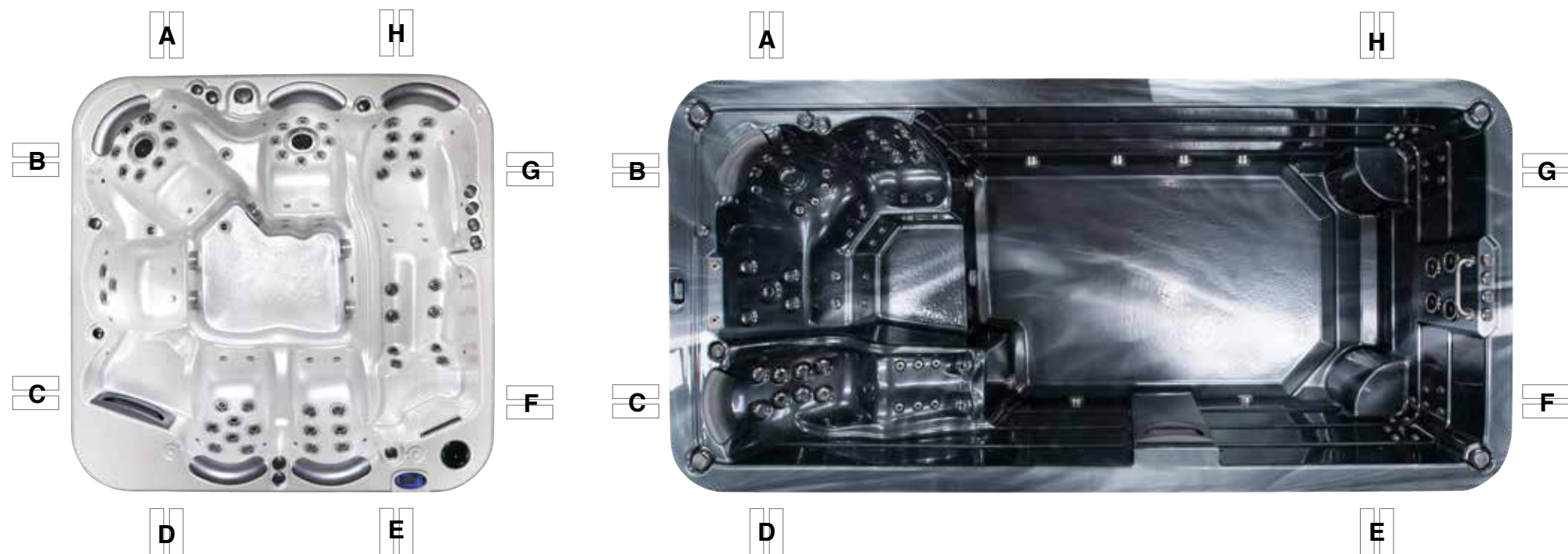

When ordering your spa with a heat&cool pump, you will need to select the best position for the pipework to exit the spa cabinet.

Keep the heat&cool pump as close as possible to the spa, but further than minimum 300mm to allow adequate air flow.

Please visit our gallery for heat&cool pump installation ideas <https://www.sapphirespas.com.au/spa-gallery/heat-and-cool-pump-installation>

NOTE: Your Spanet heat&cool pump will come with a 5m data cable. If DISTANCE FROM MAIN CONTROL BOX to heat pump is > 5.0 metres, a 10m data cable will need to be purchased and installed. If a 10m data cable is required, it will replace the 5m cable as data cable joiners can't be used as they have moulded ends.

Considerations heat&cool pump location

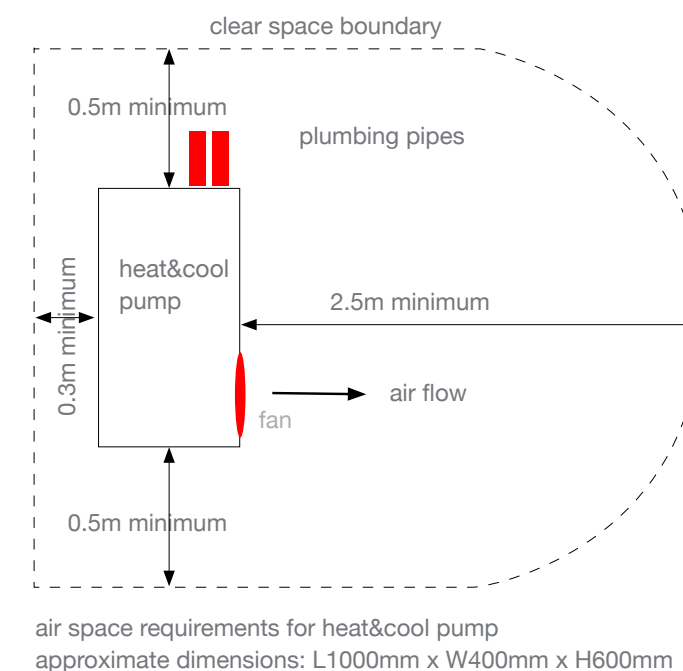

The SV series of heat&cool pumps must be located outside in a clear area where noise and air flow will not be disruptive. The heat&cool pump must be located externally to the spa pool cabinet to allow sufficient air flow for optimum efficiency.

The heat&cool pump MUST be installed according to the air space requirements shown left and the instruction manual supplied with your spa (refer inset image).

FAILURE TO FOLLOW THESE INSTRUCTIONS WILL IMMEDIATELY VOID ANY WARRANTY.

Select a suitable location in accordance with below notes and consult the local swimming pool safety regulations to check the requirements for proximity to other equipment.

1. The heat&cool pump must be situated away from vegetation and obstacles as per diagram.
2. The heat&cool pmp must be installed outside, external to the spa cabinet.
3. The heat&cool pump should be mounted on anti vibration mounts on a dead flat/level base. The base should be a large concrete slab. The base must have sufficient height to prevent entry of water into the bottom of the heat pump. The base must be large and heavy enough to properly secure the heat pump.
4. Height must be adjusted to fit the condensation drain pipe work under the heat&cool pump.
5. Do not install the heat&cool pump in a confined space to prevent recycling of air.
6. The fan should not blow towards windows, walls or spaces likely to be inhabited by people or animals.
7. Do not install where it is likely to be subjected to polluted air, dust or debris etc.
8. The heat&cool pump must operate with a clean air supply.
9. Avoid direct fan output against the dominant wind directions.
10. Protect the heat&cool pump from possible snow fall.
11. Locate heat&cool pump in a place inaccessible by children.

Spa pool & swim spa equipment access

Detail for removing the cabinet doors, plumbing location, electrical cabling conduit access (applies to all spa pools & swim spas).



Remove these screws with an allen key where applicable.



Remove the raised joiner strips which hold panels in place where applicable.



Removable side panel extends up under acrylic flange (flange is 90mm in height).



Ideal electrical conduit access through corners of spa as we've allowed 35-40mm access to enable conduit to be hidden.



Spa location considerations

Everything you need to know once you've bought your spa, where to put it at home & how to prepare for the delivery. We've gathered together some useful information for you & your tradies to get to know your way around your new spa prior to installation.

<https://www.sapphirespas.com.au/prepare-for-delivery>

Concrete & electrical connection access:

All Sapphire STANDARD / STANDARD+ / CLASSIC models come with a **4.5m power cord & 15amp plug** (manufacturer's warranty will be void if extension cords are used).

Access & preparation for delivery & crane:

Ensure you have adequate access for spa to be moved into position by trolley or lowered into position by crane.

600mm clear access all around spa or swim spa:

Please be mindful of where you position your new spa so you have access to all side panels and equipment within the cabinet.

[Access line drawings for each spa and swim spa in our range on our website:](#)

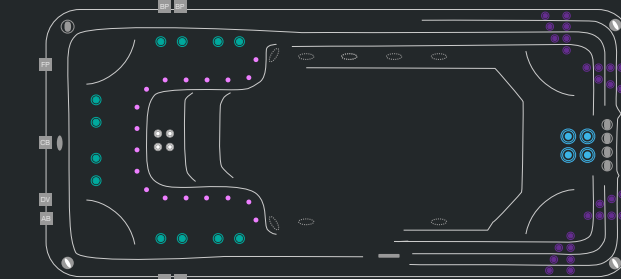

Instructions

heat&cool pump installation

The heat&cool pump will be supplied with a data and power cable already fitted.

They simply need to be connected to the Spanet SV spa control by referring to the SV Series Heat Pump Manual supplied with your spa.

Once connected, the SV controller will automatically detect the heat pump and enable its operation. Operation and use of the heat&cool pump is covered in a dedicated section of the Manual provided.

A separate power source for the heat pump is not required.



IMPORTANT NOTICE

BEWARE DIRECT UV AND SUNLIGHT EXPOSURE

Exposure of the acrylic shell of your spa to direct UV and sunlight exposure may cause excessive temperatures to build up beneath the surface and damage the spa.

Installation of spa in direct UV and sunlight may put the acrylic surface under stress and will void the warranty.

Keep the spa covered at all times when not in use to prevent and possibility of damage and voiding warranty.

Excessive heat can cause thermal crazing to acrylic surface. This is not structural but is an indication the spa surface is being exposed to extreme temperature.

BEWARE INCORRECT CHEMICAL USE

The misuse of chemicals in any Sapphire spa will void warranty.

Please ensure your chemicals are being tested correctly as per your area's water chemistry. Your local Pool & Spa specialist will be able to assist you in a spa chemical balance plan.

Sapphire Spas do not deal directly in chemicals.

If you notice your jet faces becoming lighter in colour, jet backings becoming chalky or your headrests beginning to fade, please contact the store from which the spa was purchased.

Thanks for taking the time to read our pre-delivery guide

This guide is designed to make the preparation of purchasing a sapphire spa easier. If you have any queries about anything stated in this guide, please contact your local store.

sapphirespas.com.au

sapphirespas.nz

Your local retailer

 **sapphire spas.**
australian made & family owned

